

Clarke®

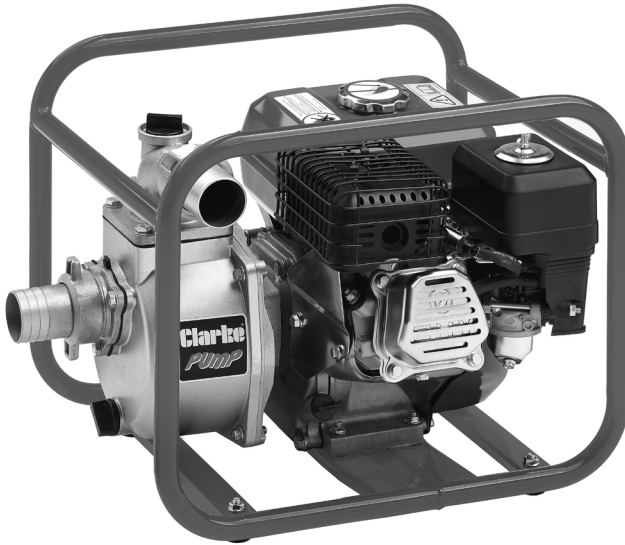

PETROL ENGINE DRIVEN 2" PUMP

MODEL NO: PW50A

PART NO: 7140651

OPERATION & MAINTENANCE INSTRUCTIONS



ORIGINAL INSTRUCTIONS

GC0819 - ISS 1

INTRODUCTION

Thank you for purchasing this CLARKE Pump.

The PW50A petrol driven pump is designed for pumping clean water, or water containing small solids in suspension. As the pump is fitted with an open impeller the suction strainer supplied must always be used to ensure that large stones or other objects cannot be drawn up, as this would cause severe damage to the pump. It is NOT designed for pumping slurry, sludge, mud or heavily polluted water, or any water containing chemicals or other acidic contaminants including salt water. This pump has the ability to pump solids in suspension no larger than 4 mm.

Before attempting to use this product, please read this manual thoroughly and follow the instructions carefully. In doing so you will ensure the safety of yourself and that of others around you, and you can look forward to your purchase giving you long and satisfactory service.

SAFETY PRECAUTIONS



CAUTION: AS WITH ALL MACHINERY, THERE ARE CERTAIN HAZARDS INVOLVED WITH THE OPERATION AND USE OF THIS WATER PUMP. EXERCISING CAUTION WILL REDUCE THE RISK OF PERSONAL INJURY.

SAFETY WHEN USING YOUR PUMP

1. Thoroughly familiarise yourself with the pump & its operation and follow all instructions in this manual.
2. ALWAYS ensure that the pump is properly positioned to prevent it moving during operation and that the immediate area surrounding the pump is kept clear.
3. ALWAYS ensure the pump cannot be started inadvertently by using the ON/OFF switch whenever carrying out maintenance or making adjustments.
4. ALWAYS use a strainer on the suction hose to prevent stones and other solids from being drawn up, which could severely damage the pump.
5. ALWAYS keep the pump dry and well clear of water discharge
6. ALWAYS use at least 300 mm of flexible hose to make pipe connections to the pump. Rigid piping may put stress on the pump causing damage. If rigid piping is used, it should be supported so as to eliminate stress.
7. ALWAYS observe all safety precautions for the handling of fuel.

8. ALWAYS use in a well ventilated area.
9. NEVER refuel the engine whilst it is running and allow the engine to cool sufficiently before refuelling.
10. NEVER use for pumping petrol (or other flammable liquids) or corrosive chemicals. This pump is designed to pump water only.
11. NEVER operate an engine driven pump in an explosive atmosphere, near combustible materials, or where there is insufficient ventilation.
12. NEVER run the pump dry. Always fill the pump with water before starting.
13. NEVER attempt any major repairs to this product unless you are qualified.
14. NEVER direct the discharge flow towards another person.
15. NEVER direct the water discharge towards electrical wiring or equipment.
16. NEVER use indoors or in a confined space.
17. NEVER over-tighten drain or filler plugs. Excessive force may damage the threads or the pump body.
18. ALWAYS use only original CLARKE replacement parts. The use of non-standard parts could be hazardous.
19. ALWAYS check for any damage or any condition that could affect the operation of the pump. Damaged parts should be properly repaired.
20. Have your pump repaired by a qualified person. Repairs should only be carried out by qualified persons using original spare parts, otherwise this may result in considerable danger to the user.

GENERAL SAFETY IN THE WORKPLACE

1. ALWAYS keep work area clean & tidy. Cluttered work areas invite accidents.
2. NEVER over-reach. Keep proper footing and balance at all times.
3. Keep other persons away. Do not let persons, especially children, touch the pump and keep them away from the work area.
4. ALWAYS ensure the workplace is well lit. Ensure that lighting is placed so that you will not be working in your own shadow.
5. Dress properly. Loose clothing or other jewellery may get caught in moving parts. Non-slip footwear is recommended. Wear protective hair covering to contain long hair.
6. ALWAYS wear safety glasses. (Everyday glasses are not safety glasses).

OVERVIEW

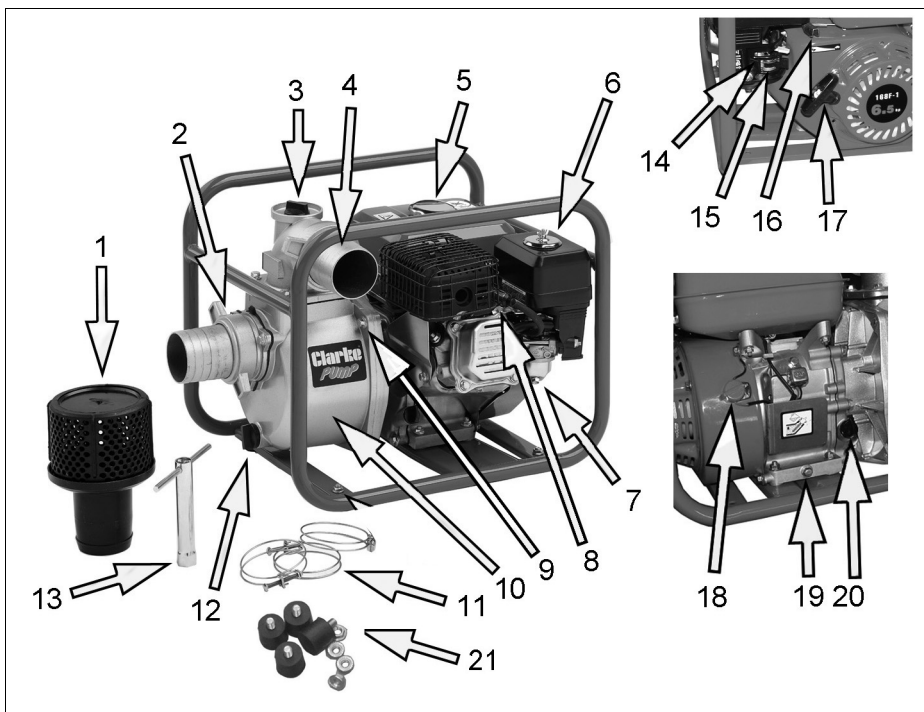

1	Inlet Strainer/filter	12	Suction Chamber Drain Plug
2	Inlet Adaptor/locking ring with O-ring	13	Plug spanner/tommy bar
3	Water Filler Plug	14	Fuel Shut-off Valve
4	Outlet Adaptor/locking ring with O-ring	15	Choke Lever
5	Fuel Filler Cap	16	Throttle Lever
6	Air Filter Housing	17	Starter Recoil
7	Carburetor Drain Plug	18	ON/OFF Switch
8	Spark Plug	19	Oil Drain Plug
9	Suction Chamber Bolt	20	Oil Filler and Dipstick
10	Inlet or Suction Chamber	21	Rubber feet/fixings
11	Hose Securing Clips		

BEFORE USE

FITTING THE FEET

1. Fit the 4 x rubber feet to the frame using the nuts and washers supplied.

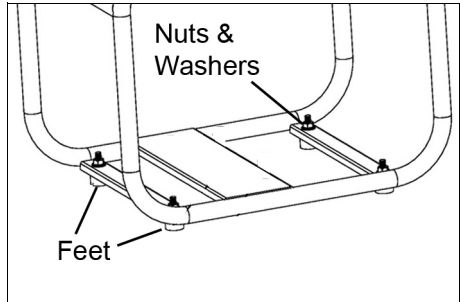

FILLING WITH OIL

This pump is not supplied containing engine oil or fuel. Use an engine oil of SAE 15-40 rating unless operating at very high or low ambient temperatures.

To fill the engine crankcase with oil:

1. Remove the filler plug/dipstick.
2. Fill the unit with oil until visible inside.
3. Check the level by inserting the dipstick back into the filler tube and checking the level is within the indicated range. If correct replace the dipstick/filler cap

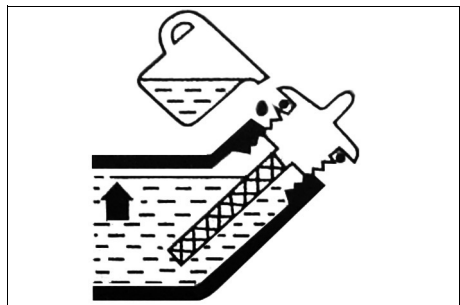
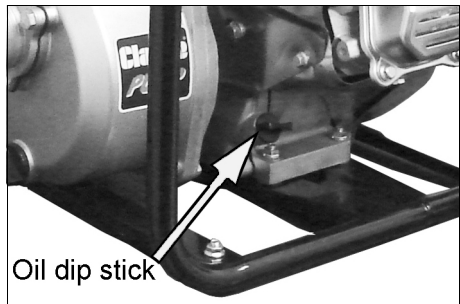

FILLING WITH FUEL



**WARNING: WIPE UP ANY SPILT FUEL BEFORE RUNNING THE PUMP.
ALLOW THE ENGINE TO COOL DOWN BEFORE REFUELLING**

- Use unleaded petrol.
1. Open the fuel cap and top up as required. Located within the fuel tank is a filter. Check this filter periodically and remove any contaminants which may have accumulated. Do not fill above the fuel filter shoulder.
 2. After refuelling, tighten the fuel filler cap securely.

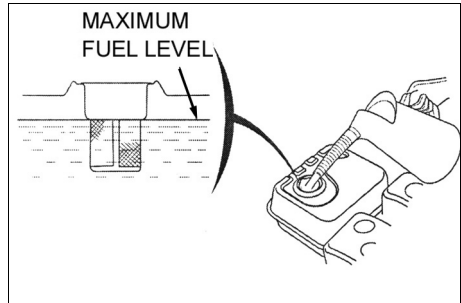

INSTALLING THE PUMP

1. Position the pump on a firm foundation and as near to the water source as possible.
2. Connect the suction and discharge hoses to the pump using the hose clamps and sealing rings supplied, to achieve an airtight seal.
 - There must be no damage to the hoses which must be adequately protected and supported.

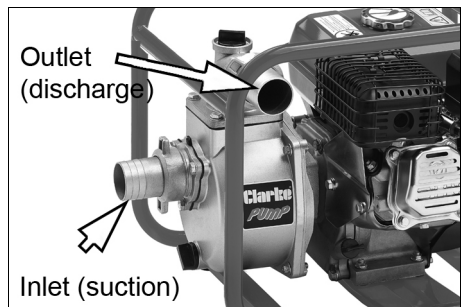

NOTE: Hoses or pipes should be supported independently and not carried by the pump.

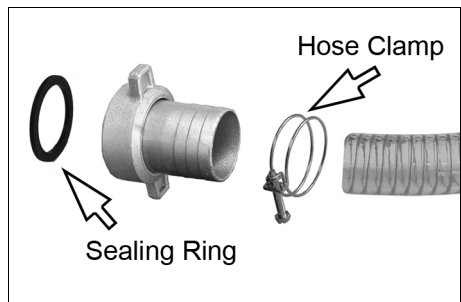

IMPORTANT: An air leak in the suction line will prevent priming, and reduce the performance of the pump.

3. Pay particular attention to the following:

- Always ensure the hose adaptor sealing ring is in place and correctly fitted.
- Always use a flexible hose at the pump body connection of at least 1ft (300 mm) length.
- Keep all pipes/hoses as short and straight as possible and avoid sharp bends. If a flexible hose must be laid across a roadway, protect it with planking.
- Ensure there is adequate drainage for the discharged water, and that there is no danger of damage to property as a result of the pumping activity.

NOTE: Instantaneous shut off pressure, applied when a vehicle runs across an unprotected hose, will cause “hydraulic shock”, which can damage the pump and/or the hose.

4. Attach the inlet strainer to the end of suction hose using a further hose clamp, to prevent large stones etc, from being drawn up which could cause severe damage. Keep the strainer free of debris.

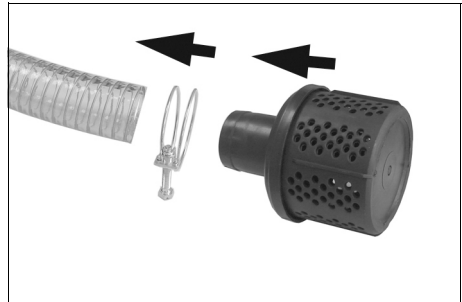

5. If it is likely to clog with dirt or debris, proceed by either:

- preparing a bed of stones on which to rest the strainer.
- tying the strainer so that it stays off the bottom of the pit, pond or excavation.
- rest the strainer inside a basket or bucket to keep undue debris away.

6. Prime the pump with water by removing the filler plug on top of the pump and filling with water, leaving no air gap.

- The pump is self-priming only when the pump is filled. It will prime and re-prime itself without refilling. Refilling is necessary only if the pump has been drained.

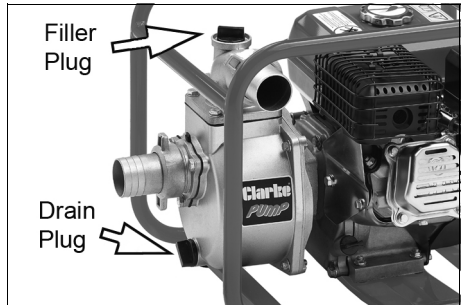

7. Never allow the pump to run dry.

8. If the discharge hose runs vertically more than 30ft a check valve should be installed in the discharge hose near the pump to stop water hammer when the pump is shut down.

- It is the pump owners responsibility to supply and install a check valve to protect the pump in this way.

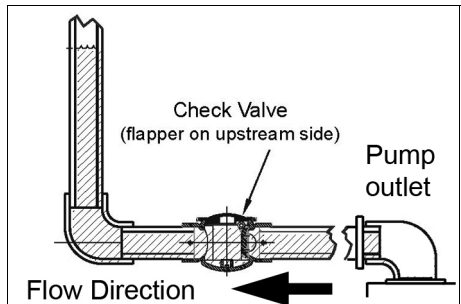

9. Properly fuelled and lubricated, the pump will run without further attention.

OPERATION



WARNING: WHEN THE ENGINE IS RUNNING THE EXHAUST MUFFLER IS VERY HOT. TAKE CARE TO AVOID BURNS. NEVER RUN THE ENGINE IN AN ENCLOSED SPACE - ENSURE THERE IS ADEQUATE VENTILATION.

Ensure the site and pump are prepared with the pump primed with water to avoid any possibility of dry running, then proceed as follows:

STARTING

- Note the markings displayed on the engine parts, for the following choke and throttle settings.

1. Set the engine On/Off switch to On.
2. Move the fuel valve to the right side (open position).
3. Pull the starter recoil rope slowly two or three times to allow fuel to reach the carburetor.
 - The direction of operation is marked on the machine.

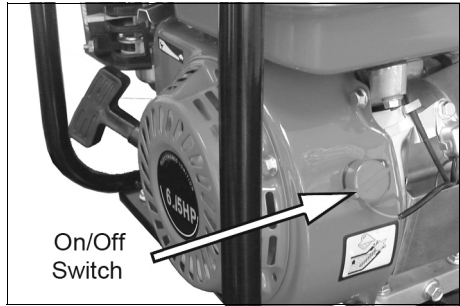

4. To start a cold engine, set the choke lever to the left (closed position), but if the engine is already warm, the choke should be in the open position to the right.

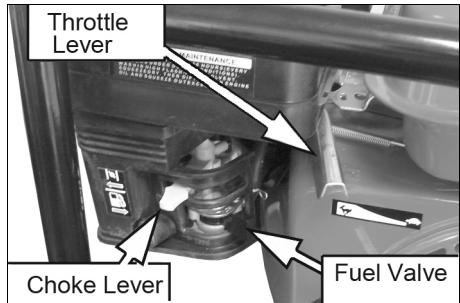

5. Set the throttle about one third open.

6. Pull the recoil starter rope firmly until the engine starts. Do not snatch at the starter rope and allow it to recoil slowly after each pull.

7. Once the engine starts, gradually return the choke to the open position as the engine warms up and use the engine throttle to gradually increase engine speed.

CONTROL DURING OPERATION

After starting the engine, move the throttle to the open position for priming of the pump and checking for pump output. Output is controlled by adjusting the engine speed.

The pump should begin discharging liquid in a few moments. To further reduce priming time, the engine speed may be increased after the engine is properly run in. If pumping does not start within this time, shut off engine and check carefully to find the problem. See TROUBLESHOOTING.

NOTE: Filling the suction pipe with water will speed up the priming process, and it is recommended that a non-return valve be fitted to the end of the suction pipe.

On higher vertical lifts, a higher engine speed is necessary but on shallow lifts or when there is little water to pump, preserve fuel and engine wear by reducing engine speed.

In the event of blockages, where debris has entered the suction chamber, the suction chamber can be opened and cleaned out by removing the bolts (12) shown in the layout on page 18.

SHUTTING DOWN

1. Reduce engine speed to minimum using the throttle lever.
2. Stop the engine by switching OFF the ignition switch.
3. Close the fuel valve.

MAINTENANCE

1. Always maintain the pump in a clean condition, checking regularly for loose bolts etc.
2. Clean the air filter once every 50 hours of use (or more often in unusually dusty conditions) as follows.
3. Unscrew the wingnut and lift off the air filter assembly from the engine.
4. Remove the components shown and clean the foam filter element with a high flashpoint solvent. Squeeze dry, then dip in clean engine oil and squeeze oil excess oil.
 - Never operate the pump without the air cleaner installed as this would cause premature wear to the engine.
5. Replace the spark plug after the first month or every 50 hours of use.

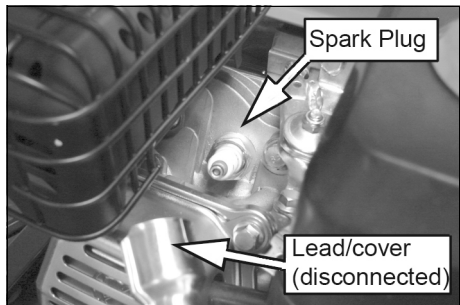
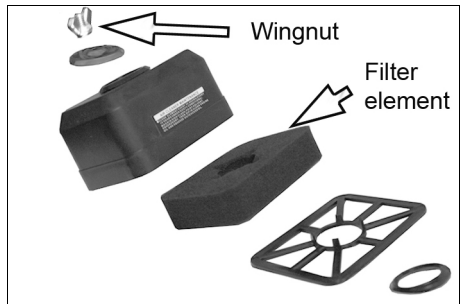

6. Check when installing that the spark plug has the correct clearance by measuring with a feeler gauge and adjusting the side electrode as required.

- Clearance should be 0.7-0.8mm.
- The recommended spark plug is LDF7RTC.

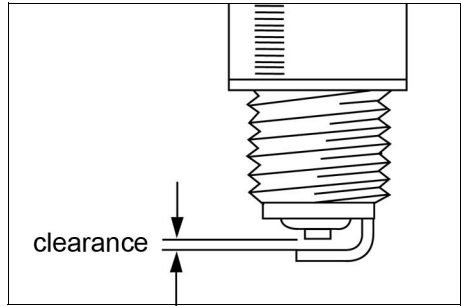

CHANGING THE OIL



CAUTION: PROLONGED EXPOSURE TO USED OIL IS HARMFUL, ALWAYS WASH YOUR HANDS THOROUGHLY AFTER HANDLING USED OIL.

The oil in the engine should be changed after the first 20 hours use and thereafter every 6 months or 100 running hours.

Remove the dipstick and drain plug and then drain the oil. Re-fill and check the level as described on page 6.

We recommend SAE15W-40 or equivalent motor oil.

ENVIRONMENTAL PROTECTION

One of the most damaging sources of pollution is oil. Do not throw away used oil with domestic refuse or flush down a sink or drain. Collect old oil in a leak-proof container and take it to your local waste disposal site.

STORAGE

After use, drain the pump body whenever there is danger of freezing, and if the pump has been used with contaminated or salty water, it should be thoroughly flushed with clean water following use, both inside and out and drained before replacing the drain plug.

Always transport the pump with the fuel cock turned off and keep the unit level to prevent any fuel from spilling.

If the pump is not to be used for some time, it should be flushed thoroughly with clean water, and drained completely before storing in a clean dry environment. Additionally, it should be prepared as follows:

1. Drain the fuel tank and carburetor completely by opening the drain plug in the carburetor float chamber and draining all remaining fuel into a suitable container ensuring the fuel shut-off valve is closed.

2. Remove the spark plug, and pour 2-3 teaspoons of light oil into the cylinder through the spark plug hole.

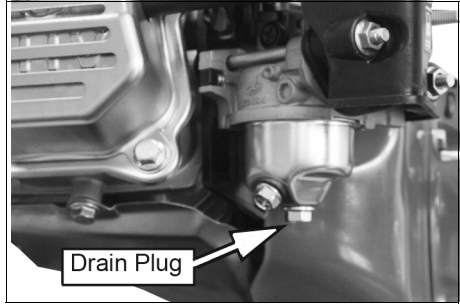

3. Pull the starter recoil rope slowly 2 or 3 times so that the oil is deposited on the cylinder walls and replace the spark plug.

- Suction and delivery hoses, additional connectors and filters are available from your Clarke stockist.

TROUBLESHOOTING

PROBLEM	CAUSE	SOLUTION
Engine fails to start	Lack of fuel in tank.	Fill tank as necessary.
	No fuel reaching carburettor.	Fuel tap is set to OFF. Turn on fuel tap.
	Engine switch is in the OFF position.	Set engine switch to the ON position.
	Lack of spark at the spark plug.	Check the spark plug cable is securely fitted to the plug. With the switch in the ON position, hold the spark plug electrode against the engine and pull the starter cord to observe the spark. If spark is present but engine will not start, consult your Clarke dealer.
Engine stops and will not re-start.	Lack of fuel in tank	Fill tank as necessary.
	Lack of oil in engine causing 'Low Oil Protector' sensor to stop engine from running.	Top up oil sump as necessary.

PROBLEM	CAUSE	SOLUTION
Pump fails to prime.	Priming chamber not filled correctly.	Fill priming chamber leaving no air gap.
	Air leaking through the suction line joints due to damaged hose, broken hose clamps, split/ill-fitting gasket.	Carry out repairs as necessary.
	Blocked inlet hose.	Clean strainer and ensure it is not submerged in mud or sediment. Ensure there are no kinks in the delivery hose.
	Engine speed too low.	Increase engine speed.
	Damaged impeller.	Dismantle pump and replace impeller.
	Air leaking through damaged seal.	Replace seal.
Low output from pump.	Engine speed too low.	Increase engine speed.
	Impellor clogged.	Clean strainer and ensure it is not submerged in mud or sediment.
	Pickup or delivery hose obstructed.	Clear obstruction and ensure there are no kinks in hose.
	High frictional losses in long inlet hose.	Avoid un-necessary curves, restrictions or valves.
	Suction lift too high.	Position pump as close as possible to the water level.
	Congested material inside pump.	Dismantle pump and clean out.
	Damaged impeller.	Dismantle pump and replace impeller.

If, after reading the troubleshooting chart you are still unable to rectify any faults, please contact your local dealer or CLARKE International for assistance.

ENVIRONMENTAL RECYCLING POLICY

At the end of its working life, do not dispose of this product or its components with general household waste. Any tools, accessories and packaging should be sorted, taken to a recycling centre and disposed of appropriately.

SPECIFICATION

Item	Spec
Product dimensions (L x W x H)	470 x 375 x 400 mm
Product Weight (kgs)	23.3 kg
Water classification	Clean/Dirty
Max solids in suspension	4 mm
Inlet/Outlet Size	2" BSP
Maximum Rated Flow	550 l/min (33m ³ /h)
Max Head	30.6 m
Suction Head	7 m
Max Pressure (Rated)	0.25 MPa (2.5 bar)
Run time @75% rated load	2.65 hrs
Engine type/speed	6.15HP (4 stroke) 3600rpm
Fuel tank capacity (petrol)	3.6 L
Lubrication oil capacity/grade	0.6 L (SAE 15W40)
Sound Pressure Level	90.89 dB LpA
Sound Power Level	103 dB LWA
Guaranteed sound power level	106 dB LWA
Uncertainty Factor (K)	3 dB

COMPONENT PARTS - GENERAL

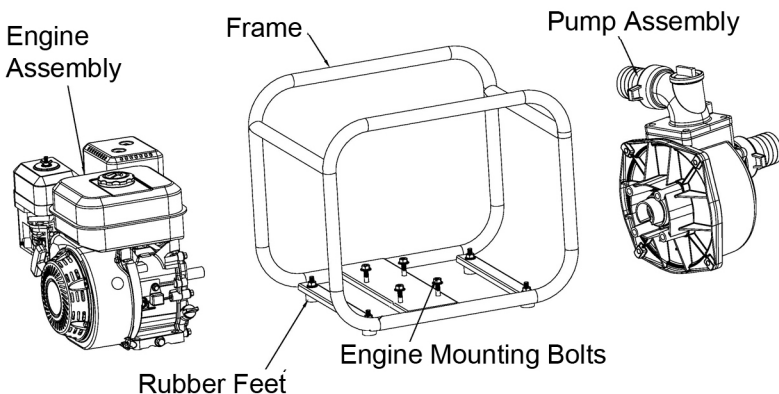

COMPONENT PARTS - PUMP ASSEMBLY

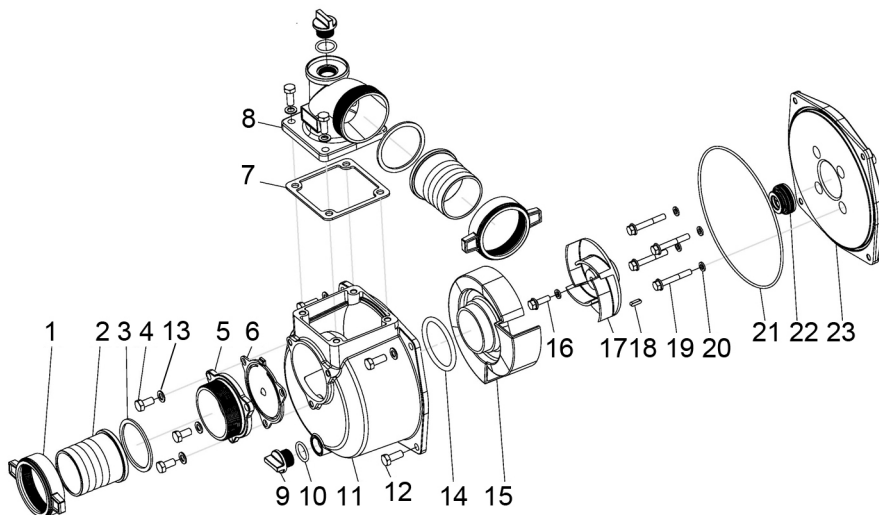

No	Description
1	Locking Collar
2	Hose Adaptor
3	Sealing Ring
4	Bolt M8 x 20
5	Water Inlet Flange
6	Check Valve
7	Gasket
8	Discharge Elbow
9	Drain Plug
10	O-Ring
11	Pump Casing
12	Flange Bolt M8 x 25

No	Description
13	Washer
14	O-Ring
15	Guide Flow Cover
16	M8 x 25 Bolt
17	Pump Impeller
18	Flat Key
19	Bolt M8 x 45
20	Sealing Ring
21	O-Ring
22	Water Seal
23	Joining Flange

COMPONENT PARTS - ENGINE ASSEMBLY

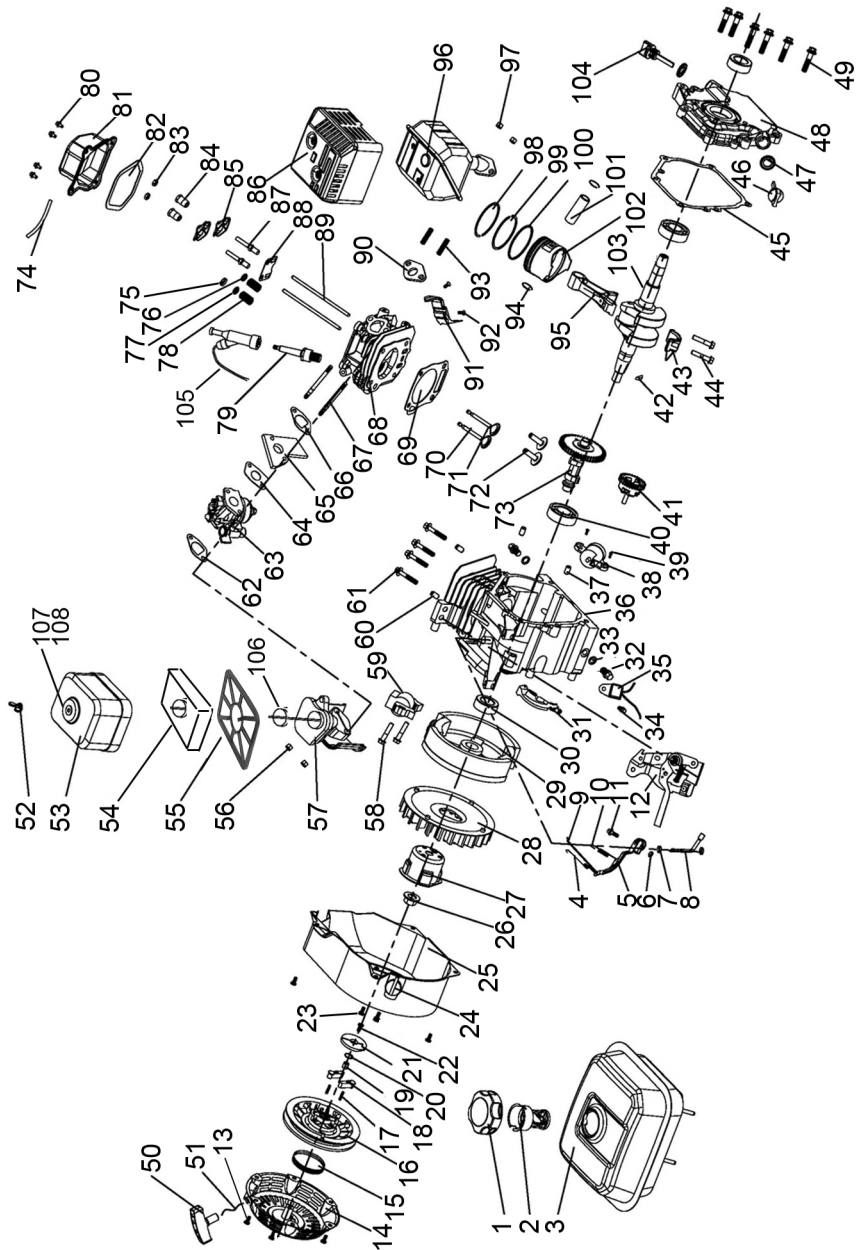

COMPONENT PARTS - ENGINE ASSEMBLY

No	Description
1	Fuel Tank Cap
2	Fuel Strainer
3	Fuel Tank
4	Tension Spring
5	Governor Arm
6	Nut M6
7	Gasket
8	Governor Lever
9	Governor Rod
10	Governor Spring
11	Bolt
12	Governor Assembly
13	Bolt M6 x 10
14	Starter Cover
15	Spring
16	Recoil Starter Assembly
17	Spring
18	Starting Pawls
19	Pin
20	Clip Spring
21	Starting Engagement Disc
22	Bolt M6 x 15
23	Bolt M6 x 12
24	On/Off Switch
25	Recoil Cover
26	Flywheel Nut
27	Starting Claw
28	Fan
29	Flywheel Assembly
30	Oil Seal

No	Description
31	Air Deflector
32	Oil Drain Plug
33	Gasket
34	M6 x 12 Bolt
35	Suppressor
36	Crankcase
37	Pin
38	Oil proximity Sensor
39	Bolt M6 x 15
40	Bearing 205
41	Governor Gear
42	Woodruff Key
43	Bearing Cap
44	Big End Bolt
45	Crankcase Gasket
46	Oil Dipstick
47	Sealing Ring
48	Crankcase Cover
49	Bolt M8 x 35
50	Starting Handle
51	Starting Cord
52	Wingnut
53	Air Cleaner Cover
54	Filter Sponge
55	Air Cleaner Base
56	Nut M6
57	Intake Duct Assembly
58	Bolt M6 x 25
59	Ignition Block Assembly
60	Cylinder Head Stud

61	Bolt
62	Gasket
63	Carburetor
64	Gasket
65	Fixing plate
66	Gasket
67	Stud
68	Cylinder Head
69	Cylinder Head Gasket
70	Exhaust Valve
71	Inlet Valve
72	Tappet
73	Camshaft
74	Rubber Tube
75	Exhaust Valve Adjusting Nut
76	Inlet Valve Spring Retainer
77	Exhaust Valve Spring Retainer
78	Valve Spring
79	Spark Plug (type LD F7RTC)
80	Bolt M6 x 14
81	Valve Cover
82	Cover Gasket
83	Nut
84	Nut

85	Rocker Arm
86	Muffler Cover
87	Rocker Bolt
88	Pushrod Retainer Frame
89	Pushrod
90	Exhaust Gasket
91	Cable Bracket
92	Screw
93	Bolt
94	Circlip
95	Connecting Rod
96	Muffler
97	Nut M8
98	Compression Ring
99	Piston Ring
100	Oil Ring
101	Small End Journal
102	Piston
103	Crankshaft
104	Oil Dipstick
105	Spark Plug Lead/Cover
106	Air Filter Seating Ring
107	Sealing Ring
108	Flanged Washer

GUARANTEE

This product is guaranteed against faulty manufacture for a period of 12 months from the date of purchase. Please keep your receipt which will be required as proof of purchase.

This guarantee is invalid if the product is found to have been abused or tampered with in any way, or not used for the purpose for which it was intended. Faulty goods should be returned to their place of purchase, no product can be returned to us without prior permission.

This guarantee does not effect your statutory rights.

DECLARATION OF CONFORMITY



Hemlock Street, Epping, Essex CM16 4UG

DECLARATION OF CONFORMITY

This is an important document and should be retained.

Product Description: 2" Inch Petrol Water Pump
Model number(s): PW50A
Serial / batch Number: 7140651
Date of Issue: 12/06/2019
(Noise Conformity)
Notified Body: N/A

Technical Documentation Holder: A.R. Pond
Clarke International
2a Strubland Road
London E10 7RB
UK

Conformity Assessment Procedure: to 2000/14/EC Annex V
Manufacturer: Clarke International
Noise Related Value: 4.6 kW
Measured Sound Power Level: 103 dB
Guaranteed Sound Power Level: 106 dB

15-0699-2.PWS0A.15-0699-2.DOC (n-2)

Page 1 of 2



Hemlock Street, Epping, Essex CM16 4UG

DECLARATION OF CONFORMITY

This is an important document and should be retained.

We hereby declare that this product(s) complies with the following directive(s):
2014/30/EU *Electromagnetic Compatibility Directive.*
2006/42/EC *Machinery Directive.*
2011/65/EU *Restriction of Hazardous substances.*
2000/14/EC *Noise Emissions Directive, (amended by 2009/88/EC).*
97/68/EC *The Emission of Gaseous and Particulate Pollutants for Internal Combustion Engines to be Installed in Non-road Mobile Machinery, (amended by 2012/46/EU)*

The following standards have been applied to the product(s):
EN 809+A1:2008, EN 55012:2007+A1:2008, EN 61000-6-1:2007, EN ISO 12100:2010.

The technical documentation required to demonstrate that the product(s) meet(s) the requirement(s) of the aforementioned directive(s) has been compiled and is available for inspection by the relevant enforcement authorities.

The CE mark was first applied in: 2015

Signed:

J.A. Clarke
Director

15-0699-2.PWS0A.15-0699-2.DOC (n-2)

Page 2 of 2

A SELECTION FROM THE VAST RANGE OF

Clarke®

QUALITY PRODUCTS

AIR COMPRESSORS

From DIY to industrial, Plus air tools, spray guns and accessories.

GENERATORS

Prime duty or emergency standby for business, home and leisure.

POWER WASHERS

Hot and cold, electric and engine driven - we have what you need

WELDERS

Mig, Arc, Tig and Spot. From DIY to auto/industrial.

METALWORKING

Drills, grinders and saws for DIY and professional use.

WOODWORKING

Saws, sanders, lathes, mortisers and dust extraction.

HYDRAULICS

Cranes, body repair kits, transmission jacks for all types of workshop use.

WATER PUMPS

Submersible, electric and engine driven for DIY, agriculture and industry.

POWERTOOLS

Angle grinders, cordless drill sets, saws and sanders.

STARTERS/CHARGERS

All sizes for car and commercial use.



PARTS & SERVICE: 0208 988 7400

E-mail: Parts@clarkeinternational.com or Service@clarkeinternational.com

SALES: UK 01992 565333 or Export 00 44 (0)1992 565335

Clarke® INTERNATIONAL Hemnall Street, Epping, Essex CM16 4LG
www.clarkeinternational.com